



**Stantec**

**NAPIER WIND PROJECT  
WIND TURBINE SPECIFICATIONS  
REPORT**

File No. 160960697  
December 2012

Prepared for:

**wpd Canada Corporation**  
2233 Argentia Road, Suite 102  
Mississauga, ON L5N 2X7

Prepared by:

**Stantec Consulting Ltd.**  
Suite 1 - 70 Southgate Drive  
Guelph ON N1G 4P5

## **Table of Contents**

---

<b>1.0</b>	<b>INTRODUCTION</b> .....	<b>1.1</b>
1.1	PROJECT OVERVIEW .....	1.1
1.2	REPORT REQUIREMENTS.....	1.2

---

<b>2.0</b>	<b>WIND TURBINES</b> .....	<b>2.1</b>
2.1	SPECIFICATIONS.....	2.1

---

<b>3.0</b>	<b>CLOSURE</b> .....	<b>3.1</b>
<b>4.0</b>	<b>REFERENCES</b> .....	<b>4.1</b>

## **List of Tables**

---

Table 1.1: Wind Turbine Specifications Report Requirements: O.Reg. 359/09 .....	1.2
Table 2.1: REpower MM92 - Wind Turbine Specifications .....	2.1

## **List of Appendices**

---

Appendix A Turbine Specifications from Manufacturer
---

## 1.0 Introduction

---

### 1.1 PROJECT OVERVIEW

wpd Canada Corporation (wpd) is a renewable energy development company based in Mississauga, Ontario, dedicated to providing renewable energy for Ontario. Further information can be found on our website at <http://www.canada.wpd.de>. wpd is proposing to develop the Napier Wind Project (the Project) in the Township of Adelaide Metcalfe, County of Middlesex, Ontario, in response to the Government of Ontario's initiative to promote the development of renewable electricity in the province. Additional information with regard to the Project can be found at <http://canada.wpd.de/projects/in-canada/napier.html>. The Project was awarded a Feed-In-Tariff (FIT) contract with the Ontario Power Authority (OPA) in July, 2011 (F-002194-WIN-130-601).

The Project Study Area includes two properties located on the north side of Napperton Drive just west of Strathroy. The proposed Project Location includes all parts of the land in, on, or over which the Project is proposed. All Project infrastructure (with the exception of collector lines in the municipal road allowance) is sited on privately owned land, where landowners have entered into a lease agreement with wpd. Permissions to access these properties have been obtained through verbal discussions with landowners, as a requirement of their signed lease agreements with wpd. The legal description of the parcels of land that will be used for the Project include the following:

- PT LT 8, CON 4, SER , AS IN 528316 ; TOWNSHIP OF ADELAIDE METCALFE/ADELAIDE
- PT LT 10, CON 4, SER , AS IN AD15467 & 77936, EXCEPT 528317 ; TOWNSHIP OF ADELAIDE METCALFE/ADELAIDE

It is of note that since the Project commenced the Study Area has been revised. The Feeder Line was originally proposed along Kerwood Road with the connection point at the Corner of Munn St. & Kerwood Rd. The Feeder Line has since been removed from the Project (the Project will connect directly into the Grid at the switching station, as described below). The Study Area has not been updated as the Natural Heritage Assessment Report/EIS and the Archaeological and Cultural Heritage Reports were completed under the original study area scenario.

The basic components of the Project include two REpower MM92-2.05 MW wind turbine generators with a total maximum installed nameplate capacity of 4.1 MW (FIT contract maximum of 5.4 MW), step-up transformers located adjacent to the base of each turbine, a 27.6 kV underground and/or overhead collector system (with associated fibre-optic cabling), a switching station and turbine access roads. On private lands, the electrical power lines will be underground; it is not yet known if the lines in the municipal right of way will be aboveground or belowground. This will be finalized as part of the municipal consultation process. Temporary

---

components during construction include work and storage areas at the turbine locations and along access roads and laydown areas.

The collector system will transport electricity generated from each turbine to a switching station located on private property at Napperton Road where it will be tied directly into Hydro One Networks Inc.'s (HONI) Distribution Network.

wpd retained Stantec Consulting Ltd. (Stantec) to prepare a Renewable Energy Approval (REA) Application, as required under Ontario Regulation 359/09 - Renewable Energy Approvals under Part V.0.1 of the Act of the Environmental Protection Act (O. Reg. 359/09). According to subsection 6.(3) of O. Reg. 359/09, the Project is classified as a Class 4 Wind Facility and will follow the requirements identified in O. Reg. 359/09 for such a facility.

## 1.2 REPORT REQUIREMENTS

This Wind Turbine Specifications Report is one component of the REA Application for the Project, and has been prepared in accordance with Item 13, Table 1 of O. Reg. 359/09 which sets out specific content requirements as provided in the **Table 1.1**.

---

**Table 1.1: Wind Turbine Specifications Report Requirements: O.Reg. 359/09**

Requirements	Completed	Section Reference
Provide specifications of each wind turbine, including make, model, name plate capacity, hub height above grade, rotational speeds and acoustic emissions data, including the sound power level and frequency spectrum, in terms of octave-band power levels.	✓	2.1

## 2.0 Wind Turbines

---

### 2.1 SPECIFICATIONS

The Project consists of two wind turbine generators (2.05 MW each) with an installed capacity of 4.1 MW (FIT contract maximum of 5.4 MW). The following table (**Table 2.1**) provides a description of the REpower MM92 wind turbine which will be used for the Project. Additional turbine specifications are provided in **Appendix A**.

Manufacturer	REpower
Model	MM92
Name plate capacity (MW)	2.05 MW
Hub height above grade	100 m
Blade length	45.2 m
Rotor diameter	92.5 m
Rotor sweep area	6,720 m <sup>2</sup>
Nominal revolutions (rotational speed)	7.8-15.0 rpm
Frequency	60 Hz
Sound power	5 m/s – 101.7 dBA 6 m/s – 103.4 dBA 7 m/s – 104.2 dBA >8 m/s – 104.2 dBA

Each wind turbine consists of the following key components:

- Concrete tower foundation;
- Five steel tower sections;
- Nacelle (comprised of gearbox, electrical generator and housing);
- Three rotor blades;
- Hub (the structure to where the blades attach);
- Power convertor;
- Step-up transformer; and
- Electrical wiring and grounding.

The tower would be supported by a concrete foundation, approximately 3 m deep, depending upon subsurface conditions. The turbine tower consists of tubular towers with flange connections. The tower height is 100 m.

The tower supports the nacelle which houses the main components of the wind turbine (comprised of gearbox, electrical generator and housing). The nacelle cover is made of glass-fibre reinforced plastic and is accessible from the tower via a hatch in the base frame. A step-up transformer, located adjacent to the base of each wind turbine, is required to transform the electricity created in the nacelle to a standard operating power line voltage (27.6 kV). The converter is located within the nacelle and controls the energy conversion in the generator by feeding power to and from the grid.

The 92.5 m rotor supports three blades and a hub. The blade design comprises a strong structure to face high wind loads but also lightweight construction to minimize the load transmission of the nacelle. This is achieved by the use of glass-fibre reinforced plastic sandwich construction. The blades are 45.2 m in length. The pitch of the blades is adjustable, allowing maximum energy input from the wind and also acting as a braking system.

A step-up transformer, adjacent to each turbine, is required to transform the electricity generated in the nacelle to a common collection system line voltage (i.e. 575 V to 27.6 kV). Each step-up transformer will be connected to the Project's collection system via 27.6 kV underground and/or overhead collector lines. The collector lines will carry the electricity to the switching station at Napperton Road where it will be tied directly into the Hydro One Networks Inc. distribution network. Turbine tower lighting would be in accordance with Transport Canada Regulations and Standards as described in the Design and Operations Report.

### **3.0 Closure**

---

This Wind Turbine Specifications Report for the Napier Wind Project has been prepared by Stantec Consulting Ltd. for wpd in accordance with Item 13, Table 1 of O.Reg 359/09.

This report has been prepared by Stantec for the sole benefit of wpd, and may not be used by any third party without the express written consent of wpd. The data presented in this report are in accordance with Stantec's understanding of the Project as it was presented at the time of reporting.

**STANTEC CONSULTING LTD.**



---

**Michael Candido**  
Project Manager

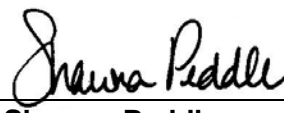

---

**Shawna Peddle**  
Senior Project Manager

## **4.0 References**

---

O.Reg.359/09 - Ontario Regulation 359/09 - Renewable Energy Approvals Under Part V.0.1 of the Act under the Environmental Protection Act.



# **Appendix A**

## **Turbine Specifications from Manufacturer**

***Repower MM92***  
***Cold Climate Version***  
***[60Hz/2050 kW]***  
Product Description

## Product Description

---

REpower Systems AG

Überseering 10

D-22297 Hamburg

Germany

Phone.: +49 - 40 - 5555090 - 0

Fax: +49 - 40 - 5555090 – 3999

[www.repower.de](http://www.repower.de)

Copyright © 2010 Repower Systems AG

All rights reserved.

Disclaimer (Canada)

Protection Notice DIN ISO 16016 : The reproduction, distribution and use of this document as well as the communication of its contents to others without explicit authorization in writing by REpower Systems AG is strictly prohibited. Offenders will be held liable for the payment of damages. Furthermore, all rights reserved in the event of the grant of a patent or industrial design.

Please ensure to use the latest versions of the applicable specifications. Images do not necessarily reflect the exact scope of supply, specifications, size or materials and are subject to technical alterations at any time. Please note that this document may not correspond with project-specific requirements.

Possible work procedures described in this product description comply with German, and REpower's, safety provisions and regulations. The national laws of other countries may provide for additional safety specifications.

It is essential that all safety measures, both project and country-specific, be strictly complied with. It is the duty of each customer to inform itself, implement and comply with these measures.

The applicability and validity of relevant legal and/or contractual provisions, technical guidelines, DIN standards and other comparable regulations are not excluded by the content or examples contained in this product description. Moreover, such contractual provisions and regulations shall continue to apply without any limitation.

All information contained in this product description is subject to change at any time without notice to, or approval by, the customer. REpower Systems AG and/or its affiliates assume no liability for any errors or omissions in the content of this product description. Legal claims against REpower Systems AG and/or its affiliates based on damage or injury caused by the use or non-use of the information included herein or the use of erroneous or incomplete information are excluded.

Although REpower Systems AG strives to provide information which is accurate and makes this information available to customers in good faith, no representation or warranty is made or guarantee given as to its accuracy or completeness. The sole applicable warranties in respect of the products described herein shall be those provided in a contract executed by an authorized representative of REpower Systems AG. EXCEPT AS PROVIDED IN SUCH EXECUTED CONTRACT, REPOWER MAKES NO WARRANTIES, EXPRESS OR IMPLIED, AS TO THE PRODUCT SPECIFICATIONS, PRODUCT DESCRIPTIONS OR THE PRODUCTS HEREIN DESCRIBED. REPOWER EXPRESSLY DISCLAIMS ALL IMPLIED WARRANTIES, INCLUDING THE IMPLIED WARRANTIES OF MERCHANTABILITY, FITNESS FOR A PARTICULAR PURPOSE, TITLE AND NONINFRINGEMENT.

All brands, trade-marks or product names mentioned in this document are the exclusive property of their respective owners.

Product Description

---

REpower Systems AG

Überseering 10

22297 Hamburg

Tel.: +49 - 40 - 5555090 - 0

Fax: +49 - 40 - 5555090 - 3999

[www.repower.de](http://www.repower.de)

Copyright © 2010 Repower Systems AG

All rights reserved.

Disclaimer (US)

The reproduction, distribution and utilization of this document as well as the disclosure of its contents to others without explicit authorization in writing from REpower Systems AG are strictly prohibited. Offenders will be held liable for the payment of damages. No license, express or implied, to any intellectual or industrial property rights is granted by these product descriptions or specifications. All intellectual and other property rights are reserved, including but not limited to industrial property rights, copyrights, trademarks, trade secrets, trade dress, or the grant of a patent, utility model, or design.

Each customer should verify that this document is the most current version of the particular product description or specification. Images contained within these product descriptions or specifications do not necessarily reflect the particular products purchased by the customer. Moreover, subject to the particular terms of any binding written contract between REpower Systems AG and the customer, the products covered by these product descriptions or specifications are subject to technical alterations at any time without notice. Please be aware that these product descriptions or specifications are for particular products and do not necessarily correspond to particular project-specific requirements.

These product descriptions and specifications comply with applicable mandatory requirements of IEC 61400, the National Electrical Code (NEC), Underwriters Laboratory (UL), and the applicable mandatory standards of the federal Occupational and Health Administration (OSHA), as well as applicable mandatory Deutsches Institut für Normung (DIN) standards to the extent they are not inconsistent with the above applicable mandatory IEC 61400, NEC, UL and OSHA standards. Customer is solely responsible for identification of and compliance with all other applicable federal, state, local, or project-specific requirements.

Subject to the particular terms of any binding contract between the customer and REpower Systems AG, REpower Systems AG: (a) reserves the right to change or modify any of the products and their physical or technical specifications without prior notice or approval by the customer or any other person; (b) disclaims all liability for any errors or omissions in the content of this product description or specifications.

EXCEPT AS MAY BE SPECIFICALLY AND EXPRESSLY PROVIDED TO THE CONTRARY IN A BINDING WRITTEN AGREEMENT BETWEEN REPOWER SYSTEMS AG AND CUSTOMER, REPOWER MAKES NO WARRANTIES, EXPRESS OR IMPLIED, AS TO THE PRODUCT SPECIFICATIONS, PRODUCT DESCRIPTIONS OR THE PRODUCTS HEREIN DESCRIBED. REPOWER EXPRESSLY DISCLAIMS ALL IMPLIED WARRANTIES, INCLUDING THE IMPLIED WARRANTIES OF MERCHANTABILITY, FITNESS FOR A PARTICULAR PURPOSE, TITLE AND NONINFRINGEMENT.

All brands or product names mentioned in this document are the property of their respective holders.

## Table of Contents

<b>Applicable Documents .....</b>	<b>6</b>
<b>List of Abbreviations and Units .....</b>	<b>6</b>
<b>List of Figures .....</b>	<b>8</b>
<b>List of Tables.....</b>	<b>8</b>
<b>1 General Information .....</b>	<b>9</b>
<b>1.1 Design Key Features .....</b>	<b>10</b>
<b>1.2 View .....</b>	<b>10</b>
<b>1.3 CCV Improvements .....</b>	<b>11</b>
<b>2 Mechanical System .....</b>	<b>12</b>
<b>2.1 Rotor.....</b>	<b>12</b>
2.1.1 Rotor Blades.....	12
2.1.2 Blade Colors and Reflectivity .....	13
2.1.3 Pitch System .....	13
<b>2.2 Nacelle.....</b>	<b>13</b>
2.2.1 Yaw System .....	14
2.2.2 Suspension Concept .....	14
2.2.3 Gearbox .....	15
<b>2.3 Tower.....</b>	<b>15</b>
<b>2.4 Deck crane .....</b>	<b>16</b>
<b>2.5 Corrosion Protection.....</b>	<b>16</b>
<b>3 Electrical System.....</b>	<b>17</b>
<b>3.1 Principle of Operation .....</b>	<b>17</b>
<b>3.2 Technical Data Low Voltage Side WEC.....</b>	<b>18</b>
3.2.1 Standard Configuration WEC .....	18
3.2.2 Grid Protection Settings Standard WEC .....	19

<b>3.3</b>	<b>Main Components</b> .....	<b>20</b>
3.3.1	Generator .....	20
3.3.2	Converter .....	21
3.3.3	External Transformer System .....	21
<b>3.4</b>	<b>House Load</b> .....	<b>21</b>
<b>3.5</b>	<b>Requirements and Standards</b> .....	<b>22</b>
<b>4</b>	<b>Safety Concept</b> .....	<b>23</b>
4.1	General Safety .....	23
4.2	Safety Chain .....	23
4.3	Brake System .....	24
4.4	Safety Equipment .....	24
4.5	Lightning Protection .....	25
4.6	Fire Safety .....	25
<b>5</b>	<b>Wind Turbine Control</b> .....	<b>26</b>
5.1	Control System .....	26
5.2	Cut-In / Cut-Out strategy .....	26
5.3	Icing Detection .....	27
5.3.1	Differential Power Curve .....	27
5.3.2	Vibration Recording .....	27
5.3.3	Optional Icing Detection .....	27
<b>6</b>	<b>Masses and Dimensions</b> .....	<b>28</b>
6.1	Weights .....	28
6.2	Dimensions .....	28

## Applicable Documents

The documents referred to in the table below are included for information only. Reference to them in this product description does not make them part of any contract between REpower and the customer or any person.

Title	Document no.
Datasheet External Transformer System [MM/60Hz/CCV/CAN]	V-2.6-EL.TR.02-B-*-EN
Datasheet External Transformer System [MM/60Hz/USA]	V-2.6-EL.TR.01-B-*-EN
Fire Safety REpower MD/MM	SD-0.0-ES.EI-4-*-EN
General Information Lightning Protection, Earthing and potential equalization [MM]	GI-2.5-EC.LP.01-A-*-EN
Standard Conditions Of Use REpower MM92 Cold Climate Version [60Hz/2050kW]	SD-2.12-WT.SC.01-A-*-EN

\* If the products referred to in the table above are to be included within the project, the relevant product descriptions in their current version shall be inserted in the contract.

## List of Abbreviations and Units

Abbreviation/Unit	Description
ETS	External Transformer System
$f_N$	Nominal frequency
GL	Germanischer Lloyd
GRP	Glass-fibre reinforced plastic
HV	High voltage (nominal grid voltage $\geq 60$ kV)
IEC	International Electrotechnical Commission
IGBT	Insulated Gate Bipolar Transistor
$I_N$	Nominal current
LV	Low voltage (nominal grid voltage $\leq 1$ kV)
MV	Medium voltage (nominal grid voltage $> 1$ kV and $< 60$ kV)
n	Rated generator speed
NEC	National Electrical Code
$P_G$	Nominal power generator

Product Description

---

P <sub>N</sub>	Nominal power WEC (nominal active power)
PPE	Personal Protective Equipment
P <sub>T</sub>	Nominal power transformer
RAL	German institute for Quality Assurance and Certification e.V.
SCADA	Supervisory Control and Data Acquisition
U	Voltage
U <sub>C</sub>	Declared high voltage (supply voltage)
UL	Underwriters Laboratories
U <sub>N</sub>	Nominal voltage
WEC	Wind Energy Converter



## List of Figures

Figure 1: Outline of REpower MM92 CCV WEC with components .....	10
Figure 2: Extended Frequency Range of REpower MM92 CCV .....	18

## List of Tables

Table 1: REpower MM92 CCV WEC main components .....	11
Table 2: Technical Data Rotor .....	12
Table 3: Technical Data Rotor Blades .....	13
Table 4: Technical Data Pitch System .....	13
Table 5: Technical Data Yaw System .....	14
Table 6: Technical Data Gear Box .....	15
Table 7: Technical Data Towers .....	16
Table 8: REpower MM92 CCV standard configuration at low voltage side of the WEC .....	18
Table 9: Standard grid protection settings at low voltage side of the WEC .....	19
Table 10: Technical data generator .....	20
Table 11: Technical data converter .....	21
Table 12: Standards .....	22
Table 13: General Data Control System .....	26
Table 14: Technical Data Cut-In / Cut-Out Strategy .....	27
Table 15: Weights .....	28
Table 16: Dimensions Blade .....	28
Table 17: Dimensions Hub .....	28
Table 18: Dimensions Nacelle .....	28
Table 19: Dimensions Drive Train .....	28

## 1 General Information

The *REpower MM92 Cold Climate Version (CCV)* is a variable speed wind energy converter (WEC) with a rated power of 2,050 kW and a rotor diameter of 92.5 m with electrical single-blade pitching system. Operational experience with more than 1.700 turbines of the *REpower MM series (MM70, MM82 and MM92)* has been incorporated in the development of the *REpower MM92 CCV*. The *REpower MM92 CCV* has been developed on the basis of the qualities of the MM series and in particular with regard to ease of maintenance, sturdy construction, generous and conservative design of the components, construction of the load-bearing structures to match the power flux and environmental compatibility.

The MM92 CCV has been optimised for operation at IEC II wind class sites (for available certifications, please refer to the document entitled "Standard Conditions of Use").

Please understand that the safe and adequate operation of a WEC requires specialized skill, knowledge and training. REpower assumes that each customer and the customer's employees, contractors and subcontractors as well as any other user, have the requisite specialized skill, knowledge and training to safely and adequately evaluate these product specifications and to properly operate the products herein described. REpower further assumes that each customer for itself, and its employees, contractors and subcontractors as well as any other user allow only well-trained individuals on the wind farm, as well as near or within the WECs. Visitors should be appropriately warned and monitored, especially in inclement weather or periods where ice may accumulate and drop from blades. No person should enter the tower or any part of the rotor or nacelle who does not have a need to assume a position within the WEC and does not possess the appropriate training and skill set to be in proximity to or perform work on, near or within a WEC. Inappropriate operation of a WEC, or untrained or undertrained individuals performing any activity on, near or within a WEC, or any type of horseplay on, near or within a WEC, may result in property damage, personal injury or death. The customer assumes the risk and responsibility for ensuring that persons allowed on, near or within any WEC possesses the appropriate skill, training and knowledge to perform whatever role brings them near within or on the WEC. REpower strongly encourages its customers to implement and enforce strict security protocols and measures to keep any individual away from WEC, other than adequately trained professionals employed by and under the supervision of the customer.

## 1.1 Design Key Features

Following the predecessor turbines *REpower MD70/77* and *MM70/82/92*, the *REpower MM92 CCV* mainly comprises the same design key features. Changes were made only where necessary to adapt the WEC to cold climate conditions (see chapter 1.3). Therefore the general design key features of the *MM92 CCV* are as follows:

- Yield-improved variable speed generator and converter system
- Fail-safe pitch system with separate control and regulation systems for each rotor blade
- 3-point suspension of mechanical drive train
- Tilted-Cone concept and pre-bent stiff rotor blades for weight balance and load transfer
- Reliable gearbox concept
- Ease of maintenance due to the spacious nacelle design

## 1.2 View

The following outline shows the side view of the *REpower MM92 CCV* nacelle with the main components and their location.

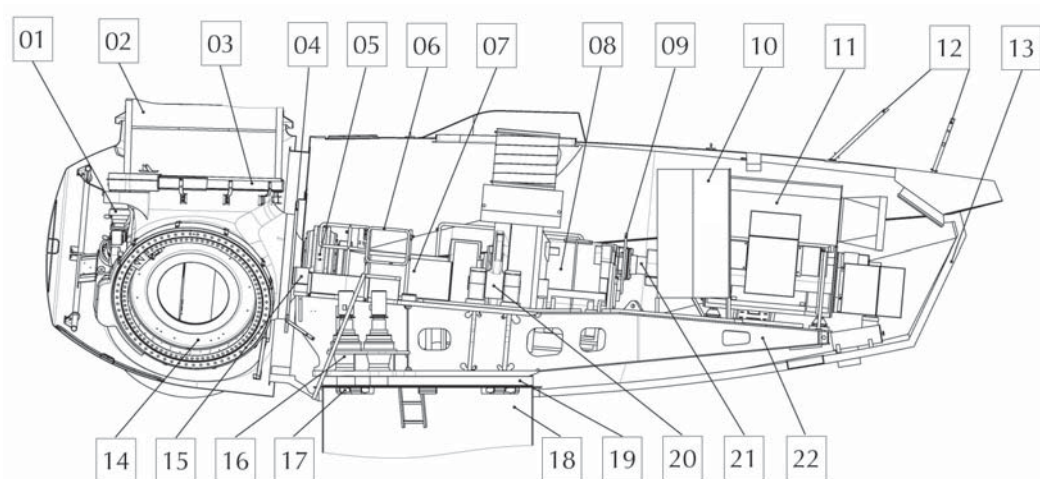

**Figure 1: Outline of *REpower MM92 CCV* WEC with components**

<b>01</b>	Rotor blade pitch system	<b>12</b>	Weather mast
<b>02</b>	Rotor blade	<b>13</b>	Nacelle enclosure
<b>03</b>	Rotor blade bearing	<b>14</b>	Rotor hub
<b>04</b>	Rotor locking disc	<b>15</b>	Rotor locking bolts
<b>05</b>	Rotor bearing	<b>16</b>	Azimuth drive
<b>06</b>	Rotor safety door	<b>17</b>	Azimuth brake
<b>07</b>	Rotor shaft	<b>18</b>	Tubular tower
<b>08</b>	Gearbox	<b>19</b>	Azimuth bearing
<b>09</b>	Rotor holding brake	<b>20</b>	Torque bearing
<b>10</b>	Top box	<b>21</b>	Coupling
<b>11</b>	Generator	<b>22</b>	Machine carrier

**Table 1: REpower MM92 CCV WEC main components**

### 1.3 CCV Improvements

To enable the WEC to be installed and operated under cold climate conditions, the MM92 CCV is modified in certain relevant parts and components:

- Low-temperature grease, e.g. for rotor bearing
- Low-temperature hydraulic oil, e.g. for yaw brakes
- Low-temperature lubrication system, e.g. for blade bearing
- Low-temperatures materials, e.g. for blade pitch gearbox and deck crane
- Improved and/or additional heating elements, e.g. for top box, generator and gearbox oil system
- Modified cabinet for top box and base box
- WEC control via laptop interface at top box and base box
- Ultrasonic anemometer for measurement of wind direction and speed
- Low-temperature steel at the door frame and partially increased steel thickness for the tower
- Liquid-cooled converter
- Intelligent heating process to accelerate and secure the re-start of the WEC after a shutdown at low temperatures

The environmental conditions are described in the document “Standard Conditions of Use”.

## 2 Mechanical System

### 2.1 Rotor

The rotor consists of three rotor blades that are flange-mounted on the cast hub via a blade bearing. The rotor blades can thus be adjusted along their longitudinal axis via the pitch drives. In order to provide continued operation of the pitch system in the event of grid loss or WEC malfunction, each blade has its own independent power supply system using a storage battery set and controller.

In the partial load range, i.e. when the WEC is operated below the rated power, it works at a constant blade pitch and variable speed to exploit optimal rotor aerodynamics. Within the nominal load area, i.e. when the WEC has reached its maximum rotor speed, it operates with a constant nominal torque which is given by the generator. Changes of the wind speed are controlled by the pitch system.

Technical Data Rotor	
Rotor diameter:	92.5 m
Swept area:	6,720 m <sup>2</sup>
Speed range:	7.8 to 15.0 (+12,5 %) rpm
Maximum tip speed:	approx. 72.6 m/s
Rotor axis inclination:	5 °
Rotor cone angle:	3.5 °
Direction of rotation:	clockwise
Rotor position:	up-wind

Table 2: Technical Data Rotor

#### 2.1.1 Rotor Blades

The blade design for the *REpower MM92 CCV* comprises a strong structure to face high wind loads but also lightweight construction to minimize the load transmission to the nacelle. This is realized by the use of glass-fiber reinforced plastic (GRP) sandwich construction which provides the needed material properties.

The blades have also been improved for high aerodynamic efficiency and thus to reduce the noise emissions of the WEC. The UV-resistant gelcoat surface of the blades protects the blade structure against penetration of moisture. Also on certain areas like the front-edge of the blade, special protection measures have been taken to avoid erosion. Depending on the type of installed blade, the blade can either be equipped with additional aerodynamic add-ons such as stall barriers and spoilers, but can also have a different shape, which includes these improvements in the blade design itself.

Please note, that REpower Systems AG reserves the right to select and modify, at its sole discretion, the manufacturer or type of blades without consulting the customer.

Technical Data Rotor Blades	
Number of rotor blades:	3
Rotor blade Length:	approx. 45.2 m
Blade material:	Glass-fibre reinforced plastic (GRP)

**Table 3: Technical Data Rotor Blades**

### 2.1.2 Blade Colors and Reflectivity

The blades are light grey (RAL 7035) which is a pale standard color. It minimizes reflectivity of a blade efficiently while having no influence on the power curve. Furthermore, the blades can be colored with different red markings, which are available as an option.

### 2.1.3 Pitch System

As described in chapter 2.1, the blades are flange-mounted on the hub via a blade bearing so that they can rotate along their longitudinal axis. The rotation of the blades is performed by pitch drives which are individually attached to each blade and feature individual controller systems. In order to synchronise the individual blade adjustments, an additional synchronisation controller is used. The safe operation of the turbine in event of grid loss or WEC malfunction is ensured by independent uninterrupted power supplies for each pitch drive.

Technical Data Pitch System	
Principle:	electrical-drive, single blade pitch
Power control:	pitch and rotor speed control
Pitch drives:	synchronised DC motors with battery buffer
Maximum blade angle:	91 °
Pitch rate at safety shut-down:	approx. 6-7 %/s

**Table 4: Technical Data Pitch System**

## 2.2 Nacelle

To meet today's demands on an innovative WEC, the cabin has been designed by a renowned industrial design firm. The result is an aerodynamic design which has been generously dimensioned to create sufficient conditions for service and maintenance. Maintenance work can be carried out with the nacelle closed, although it is also possible to open the nacelle for a replacement of bigger components.

The nacelle is accessible from the tower via a hatch in the base frame. A maintenance platform has also been installed to ensure that the components below the base frame can also be accessed as easily as possible.

All components, such as the yaw system or the hydraulics, can be operated from the control system in the nacelle. An emergency stop button has been installed for safety reasons. Furthermore, all moving parts within the nacelle are covered to minimise the risk of injuries.

For the housing material, glass-fiber reinforced plastic (GRP) was chosen, as it offers reliable protection and is also very light. Like the blades, the nacelle is also coloured light grey (RAL 7035).

### 2.2.1 Yaw System

The nacelle is connected to the tower via a contact bearing. Yawing of the nacelle is achieved by means of electrical yaw drives. Hydraulic brake calipers keep the nacelle in the wind direction and keep the yaw drives substantially free of loads which might occur from inflow angles in horizontal or vertical axis. The brakes are also active in a non energized state.

An electronic wind direction sensor with corresponding software controls the switch-on times and direction of rotation of the motors. It also ensures an automatic cable untwist if the nacelle changes its position several times in one direction as a result of changing wind conditions. While the WEC is yawing the brakes are released. Once it has been adjusted towards the wind, the brakes are activated and keep the position of the WEC.

Technical Data Yaw system	
Principle:	electrical geared drives, hydraulic yaw brakes
yaw rate:	approx. 0.5 °/s
bearing:	contact bearing with external toothings

**Table 5: Technical Data Yaw System**

### 2.2.2 Suspension Concept

The drive train is supported at three points immediately above the head flange of the tower, whose conical geometry provides a wide basis to absorb the loads. The fore side suspension is carried out by a generously dimensioned spherical roller bearing. The two other suspension points are the torque arms of the gearbox which are balanced by elastomer bushings. Together with the three point suspension, the “tilted-cone” concept and an inclination of the rotor shaft by approximately 5% provides a load transfer into the tower, along with a significant tolerance of the drive train alignment.

### 2.2.3 Gearbox

The gearbox is designed as a combined planetary / spur gear. The tothing has been improved with respect to efficiency and noise emission. Elastic bushings are integrated in the torque arm of the gear that rest on the base frame via support pieces. The elastic bearing allows an effective sound and vibration decoupling from the main frame. The gearbox design fulfils partly higher requirements and safety factors than given in the ISO 81400-4 (Issue 2005-10). Furthermore, the gearbox is equipped with an electrical and a mechanical oil pump to ensure sufficient oil flow, even under idling conditions.

The gearbox contains an oil particle counter which detects metalliferous particles in the gearbox oil. This system helps identify abrasion of toothings and bearings at a very early stage and thus help preventing a significant damage of the gearbox by taking counter-measures in time.

Technical Data Gearbox	
Principle:	planetary/helical gear system
Mechanical nominal power at rotor shaft:	2,165 kW
Gear ratio:	$i = 96.0$
Direction of rotation:	clockwise
Axis inclination:	$5^\circ$

**Table 6: Technical Data Gearbox**

## 2.3 Tower

The tower is designed as a conical tubular steel tower consisting of three to five segments, depending on the hub height as stipulated in the sales contract. Like blades and nacelle it is coloured in light grey (RAL 7035). Each tower features a lockable door which allows access for authorised persons to the tower base. A ladder inside the tower gives access to the nacelle and is equipped with a fall protection system. Depending on the hub height of the tower, there are various numbers of platforms at different heights to allow resting and to provide shelter in case of an emergency. The platforms are equipped with additional safety lights.

The cabinets for the converter are mounted in the tower base on a separate platform. The generator power is transferred to the tower base via shielded bus bars and a power cable system. Control signals for the WEC control system are transmitted via optical glassfiber cables inside the tower to comply with electromagnetic compatibility (EMC) requirements.



Technical Data Towers	
Type:	conical tubular steel tower
Hub heights *:	78.0 – 80.0 m
Diameter of head flange:	approx. 3.0 m
Diameter of bottom flange:	approx. 4.6 m

\*The hub heights depend on the foundation design and extension

**Table 7: Technical Data Towers**

## 2.4 Deck crane

The nacelle also features a deck crane, which can be used for maintenance tasks to lift tools or components weighing up to 250 kg. The back of the nacelle features a crane hatch which is secured with a safety gate. The deck crane should not, under any circumstances, be used for lifting persons.

## 2.5 Corrosion Protection

All parts of the WEC are protected against corrosion and other environmental influences by a special multilayer coating. The coating system complies with requirements of DIN EN ISO 12944.

## 3 Electrical System

### 3.1 Principle of Operation

The WEC is equipped with a variable speed generator/converter system. This allows the speed to be adjusted within a range of +/-40% of the synchronous speed (including dynamic range). The combination of variable speed operation and electrical pitch adjusting system helps to provide very good results with regard to energy yield, efficiency, mechanical stressing and power quality. The system avoids surges and peak loads. Operating control provided by the generator allows uniform power export with minimal fluctuation in the partial load range. The WEC can be operated at nearly constant power in the nominal load range. The general ability to generate reactive power also allows targeted management of reactive power in accordance with customer and network operator requirements with the addition of optional products.

The functional principle of REpower's variable speed generator is based upon the concept of the doubly-fed asynchronous generator with a converter which takes advantage of IGBT technology. The system assures continuous power generation with voltage and frequency matched to the grid, regardless of rotor speed. Speed and power are adjusted automatically according to the prevailing wind speed. The WEC operates in the following operating ranges depending on the prevailing wind speed:

- ▶ In the sub-synchronous operating mode (partial load range) the generator feeds 100% electrical power to the grid. In addition, slip power is supplied to the rotor from the converter via the generator's slip rings.
- ▶ In the over-synchronous operating mode (nominal load range), the generator feeds approximately 83% electrical power directly to the grid, which does not have to be fed via the converter. Remaining power (approx. 17%) is fed to the grid from the rotor via the frequency converter.

Amongst the various advantages of this system, are the low loss which assures high overall efficiency, and outstanding availability due to the compact design with a minimal number of components.

### 3.2 Technical Data Low Voltage Side WEC

#### 3.2.1 Standard Configuration WEC

The REpower **MM92 CCV standard configuration** is described at table 8 and table 9.

Parameter	Value
Nominal active power	$P_N = 2050 \text{ kW}$
Power factor	$\cos \varphi = \sim 1$
Nominal voltage	$U_N = 575 \text{ V}$
Voltage range (at LV terminals) <sup>1</sup> of the WEC ( $\cos \varphi = \sim 1$ )	$90\% \leq U_N \leq 110\%$
Nominal frequency	$f_N = 60 \text{ Hz}$
Current ( $\cos \varphi = \sim 1$ ; $U_N$ )	$I = 2058 \text{ A}$
Rated generator speed	$n = 1440 \text{ min}^{-1}$

**Table 8: REpower MM92 CCV standard configuration at low voltage side of the WEC**

The REpower WEC stays connected to the grid within the frequency and related time limits described in figure 2. During this time the voltage has to be close to nominal voltage. Figure 2 describes *Extended Frequency Range* for active power production.

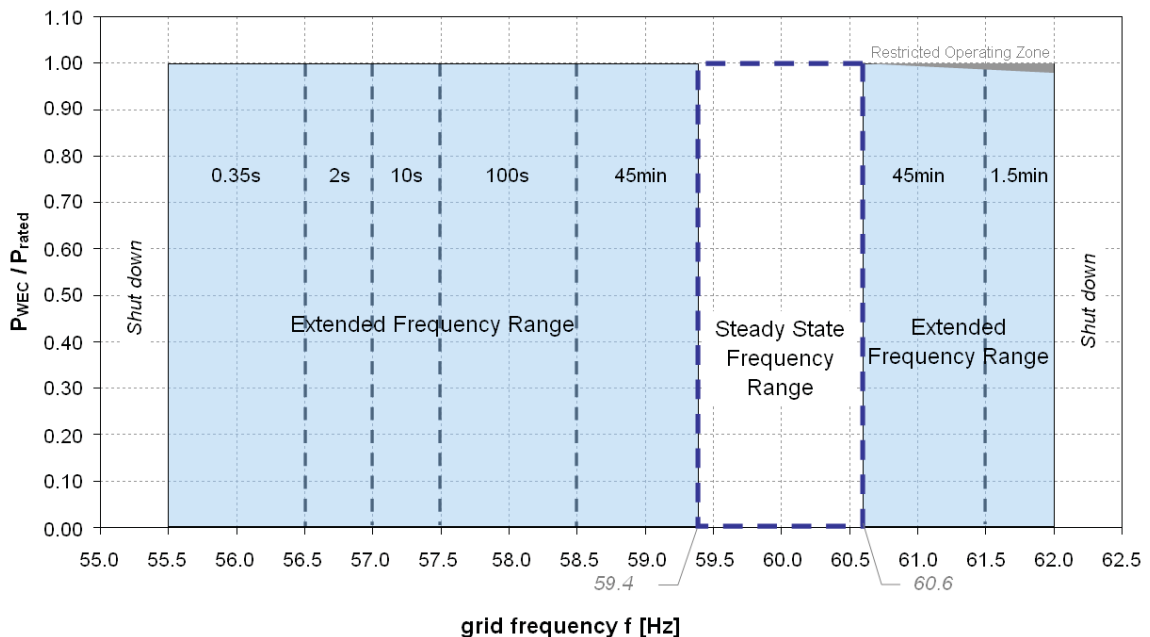

**Figure 2: Extended Frequency Range of REpower MM92 CCV**

<sup>1</sup>The automatic tap changer of the wind farm transformer in the medium-voltage system must assure that line voltage does not drop below nominal voltage for a longer period of time. If the line voltage is below nominal voltage for a longer period of time electrical power production could be reduced.

Within the Restricted Operating Zone in figure 2 an active power reduction down 97.5% of rated active power is possible. The reactive power production may also be affected in the *Extended Frequency Range*.

**By adding optional *REpower Grid Products* and/or *REguard Products* electrical capabilities and control functionalities for the single WEC and/or the wind farm can be extended, to fulfil project specific network requirements and manage power plant tasks within the wind farm.**<sup>2</sup>

### 3.2.2 Grid Protection Settings Standard WEC

To identify single-phase and three-phase faults the WEC control includes grid monitoring to measure the current and voltage in all phases. The grid monitoring analyses the current, voltage and the fluctuation of the respective values in time to disconnect the generator and converter immediately from the grid if necessary and disconnect the WEC from the grid if any of the events in table 9 occur.

Trigger Event	Trigger Value	Comments
Maximum voltage [U >] (symmetrical/asymmetrical)	$1.1 \cdot U_N$	Setting values shall be defined together with the responsible network operator
Minimum voltage [U <] (symmetrical/asymmetrical)	$0.90 \cdot U_N$	Setting values shall be defined together with the responsible network operator
Maximum frequency [f >]	60.6 Hz	Setting values shall be defined together with the responsible network operator
Minimum frequency [f <]	59.4 Hz	Setting values shall be defined together with the responsible network operator
Phase jump	$\pm 6^\circ$	Undelayed triggering

**Table 9: Standard grid protection settings at low voltage side of the WEC**

The standard grid protection settings for minimum and maximum voltage can be investigated and adjusted for each specific project depending on the additional *REpower Grid Products*.

The standard grid protection settings for minimum and maximum frequency are adjustable parameters which can be set within the frequency range described at figure 2.

In case of an event in table 9, the WEC will resume to normal operation after grid recovery.

<sup>2</sup> Corresponding values described in table 8 and table 9 shall change if optional products are chosen.

### 3.3 Main Components

#### 3.3.1 Generator

Technical Data Generator	
Concept:	Asynchronous doubly-fed generator with rotor power recovery to the grid via the frequency converter. The stator winding is synchronized to the low-voltage side and is connected directly to the grid with a soft cut-in.
Nominal power / speed:	$P_G = \sim 2080 \text{ kW}$ at $n = 1440 \text{ min}^{-1}$ ( $\pm 20 \text{ kW}$ depending upon manufacturer)
Speed range:	$n = 720$ to $1440 \text{ RPM}$ (dynamically up to $1680 \text{ min}^{-1}$ )
Type:	6-pole, 3-phase asynchronous doubly-fed generator
Model:	IM B3 acc. to DIN IEC 60034 code I IM 1001 acc. to DIN IEC 60034 code II
Size:	500
Protection:	IP 54, enclosure of slip ring IP 23
Cooling:	Surface mounted air-air heat exchanger. External airflow is generated by an external fan. Cooling air is drawn from inside the nacelle.
Sensors:	PT 100 for monitoring bearings PT 100 for monitoring coils Brush wear warning
Miscellaneous:	Covers reduce the risk of contact with rotating parts.  The generator housing is earthed for potential compensation.  The generator is borne on sound and vibration-decoupling elements on the base frame for reasons of sound insulation and decoupling.

**Table 10: Technical data generator**

### 3.3.2 Converter

Technical Data Converter	
Concept:	Frequency converter for asynchronous, double-fed generator with DC intermediate link.
Function:	Control/regulation of active and reactive power. Recovery of rotor power via generator and grid side inverters.
Power semiconductors:	IGBTs
Protection:	IP 54, inductor cabinet: IP 21
Cooling:	Forced air cooling of converter compartment. Liquid cooling system for IGBTs.

**Table 11: Technical data converter**

### 3.3.3 External Transformer System

The medium voltage transformer and switchgear are not included in REpower's scope of supply, but have to fulfil the REpower requirements described in the document "Datasheet External Transformer System [MM/60Hz/USA]" for USA and "Datasheet External Transformer System [MM/60Hz/CCV/CAN]" for Canada.

Note: Rated power of transformer must be chosen according to reactive power capability of the WEC. Nominal voltage transformer must be chosen according to the nominal grid voltage of the wind farm.

## 3.4 House Load

Power required by the WEC in the standby mode is comprised of the individual requirements of the following components:

- ▶ Controls (control computer and converter)
- ▶ Yaw drives
- ▶ Hydraulic pump
- ▶ Heating for gearbox, generator and control cabinets
- ▶ Battery charger
- ▶ Pitch control drive units during self-test and start-up
- ▶ Motor power at shutdown wind speed

Power requirements do not exceed approximately 50 kW (10 minute mean value). House load depends to a great extent upon location. Energy requirements are particularly high when wind speed is lower than cut-in wind speed in combination with the requirement for cold climate specific component heating. Values may fluctuate between coastal and inland locations. An estimate of up to approximately 16000 kWh per year can be assumed at locations with medium wind speeds, although deviations, both upward and downward, are possible. These specifications do not take upstream components into consideration (e.g. transformer and auxiliary equipment, as well as medium and low-voltage cabling).

### 3.5 Requirements and Standards

Following components (1 to 5), installed in the tower basement of the WEC, comply with the requirements of the respective standards listed at Table 12.

- 1 Converter System
- 2 Basement Box (local control system, communication, measurement)
- 3 Power cable
- 4 Control Cable
- 5 Busway

No.	Name	Title
/NR-1/	NFPA 70 (2005 Edit.)	National Electric Code
/NR-2/	NFPA 79 (2007 Edit.)	Electrical Standard for Industrial Machinery
/NR-3/	UL 508 A - Edit. 1 (2001-04)	Standard for Industrial Control Panels
/NR-4/	UL 508 C – Edit. 3 (2002-05)	Standard for Power Conversion Equipment
/NR-5/	UL 857 – Edit. 12 (2001-01)	Standard for busway line
/NR-6/	CSA C22.1	Canadian electrical code Part 1
/NR-7/	CSA C22.2	Canadian electrical code Part 2

**Table 12: Standards**

It is customer's responsibility to determine whether there are any additional or different requirements imposed by federal, provincial, state or local governments, including special districts if any, in which the project is located.

## 4 Safety Concept

### 4.1 General Safety

Like all other REpower WEC the *REpower MM92 CCV* is designed for a high level of operational safety. REpower WECs comply with the mandatory applicable requirements of the U.S. federal safety standards established by OSHA. Since REpower WECs are designed to comply with these mandatory applicable U.S. federal standards, the customer is responsible to determine whether there are any additional or different requirements imposed by federal, provincial, state or local governments, including special districts if any, in which the project is located.

The WEC is equipped with safety devices and sensors that are used for the protection of individuals and the turbine, as well as for its control. This in particular includes:

- ▶ “Fail-safe” aerodynamic brake by the use of independent blade adjustment system
- ▶ Turbine controller independent safety chain
- ▶ Protection against external emission of liquids by the use of labyrinths and collecting trays
- ▶ Coverage of rotating parts in the WEC for the safety of individuals
- ▶ Generous space in the nacelle for service and maintenance
- ▶ Internal access to the hub from the nacelle

### 4.2 Safety Chain

The safety chain is a hard-wired circuit in which all contacts for triggering an emergency stop are connected in series. If the safety chain is interrupted, the WEC will stop immediately. A reset can only be done when the cause of the interruption has been rectified (except for emergency stops due to grid loss).

The following safety chain contacts can trigger an emergency stop:

- ▶ Emergency stop button on top box (nacelle)
- ▶ Emergency stop button on portable control unit (nacelle)
- ▶ Emergency stop button on the switching cabinet in the tower base
- ▶ Overspeed switchgear for rotor speed
- ▶ Overspeed switchgear for gearbox speed



- ▶ Vibration switch
- ▶ Cam switch (azimuth revolutions counter)
- ▶ Service key switch on the top box
- ▶ Hardware contact on the system management computer

### **4.3 Brake System**

The brake system consists of the primary aerodynamic brake system and of the secondary mechanical brake system.

The aerodynamic brake system includes the three blades of the WEC, each equipped with individual controllers, pitch drives and emergency power supplies. Aerodynamic braking is carried out by adjusting the rotor blades in the feathering position. This is done dynamically with the possibility of using different pitch speeds thus avoiding possible load peaks. Each of the three pitch systems on the rotor blade can also operate independently. In the event of grid loss the pitch systems are supplied via their respective individual emergency power supply.

The brake force of a single blade is enough to bring the WEC into a safe speed range. This leads to an increased safety system.

The mechanical rotor holding brake system is installed at the high-speed shaft as an active system. It is activated if the primary safety system fails partially or totally and stops the rotor in conjunction with the blade adjustment system. It is also used to fix the rotor once the aerodynamic braking system has stopped to secure the rotor during maintenance work.

The braking system is designed for a "fail-safe" function. This means that in case of a malfunction or failure of one component within the braking system, the WEC immediately switches to a safe status.

### **4.4 Safety Equipment**

One set of lift abseiling equipment with accessories for platform rescue is available in each nacelle which can be used to evacuate the WEC in the event of an emergency.

#### **4.5 Lightning Protection**

The WEC is equipped with a comprehensive lightning protection and earthing system in accordance with IEC 62305 (2006-01) and IEC 61400-24 Ed.1 (2010-06) which is used to protect the WEC from direct (e.g. lightning strike) or indirect damage. The receptors of the blades, the spinner, the nacelle and the lightning rod receive the lightning and subsequently discharge the lightning current via defined paths to the ground. The electrical as well as electronic components of the WEC are protected against interfering fields and disturbance voltage by overvoltage arresters.

Further information is provided in the document "General Information Lightning Protection, Earthing and potential equalization [MM]".

#### **4.6 Fire Safety**

The measures taken to improve fire safety are described in the document entitled "*Fire Safety REpower MD/MM*".

## 5 Wind Turbine Control

### 5.1 Control System

The micro-processor based control system *REguard Control B* of the *REpower MM92 CCV* is part of the *REpower SCADA system REguard* and allows the integration of the WEC into the *REpower SCADA system REguard*. The access to the control system *REguard Control B* has to be equipped with the optional *REguard Monitoring*. *REguard Monitoring* allows direct access to the turbine controller *REguard Control* and other *REguard* devices installed at the site, such as *REguard Power Management Unit* or *REguard Meteo Station*. Depending on the user level, the *REguard Monitoring* visualizes current operational as well as historical data which is stored on the turbine controller in the nacelle and at the tower base.

For more information about the *REguard Control System*, please refer to the respective product descriptions of the *REguard SCADA System*.

General Data Control System	
Principle:	micro processor
Remote Control:	<i>REguard Monitoring</i>

**Table 13: General Data Control System**

### 5.2 Cut-In / Cut-Out strategy

The Cut-In procedure will be initiated only if all operational systems are ready to operate and the Cut-In wind speed is reached or exceeded for 60 seconds. If the conditions for automatic start are met and the previous cause for a stopping procedure has been taken into account, the rotor shall be accelerated by pitching the blades.

The Cut-Out procedure will be initiated only if the wind speed is above the given Cut-Out wind speed within the 10 minute average. After a Cut-Out due to exceedance of Cut-Out wind speed the WEC restarts when the wind speed is 22 m/s within the 10 minute average. However, to cope with extreme gusts, the WEC shall also start the Cut-Out procedure if the wind speed is higher than 30 m/s within the 30 s average and higher than 35 m/s within 1 s. The stopping procedure will pitch the blades into the feathering position and bring the WEC to a safe stop.

The design parameters for operation are within the following range of 10 minute average wind speeds:

<b>Technical Data Cut-In /Cut-Out Strategy</b>	
Cut-in wind speed:	3.0 m/s
Rated wind speed:	12.5 m/s
Cut-out wind speed:	24.0 m/s

**Table 14: Technical Data Cut-In / Cut-Out Strategy**

### 5.3 Icing Detection

Ice can accumulate on blades and lead to unbalance and higher loads on blades, bearings and drive train. In order to avoid damage to the WEC and prevent ice throw, following measures are used to stop the WEC:

- ▶ Differential power curve
- ▶ Vibration recording

Shutdown and restarting of the WEC are recorded in the operating computer's event protocol and are available for subsequent verification purposes.

#### 5.3.1 Differential Power Curve

If ice layers accumulate on the rotor blades during operation, the lift behaviour of the blades is strongly influenced and thus the performance of the WEC. The power curve of the WEC is recorded with the operating computer and is constantly checked for plausibility.

If a threshold value for the deviation between the standard power curve and the actual has been reached or exceeded, a stop is initiated by the controller. After a manual reset the WEC is ready for operation.

#### 5.3.2 Vibration Recording

If additional rotor blade loads occur due to icing, tower vibrations develop which are monitored by the operating computer. In this event a stop of the WEC is initiated by the controller. The WEC is made ready for operation again by a manual reset.

#### 5.3.3 Optional Icing Detection

REpower offers optional Icing Detection solutions. Please contact your REpower sales partner for more information.

## 6 Masses and Dimensions

The *REpower MM92 CCV* is generally designed for relatively easy transport and erection. Therefore, the weights are roughly kept at the same level as the MD-series. The possibility to install the nacelle and the drive train separately allows the use of the same crane equipment as for the MD-series. The values given in chapter 6.1 and 6.2 are for information purposes only and may vary from the actual values.

### 6.1 Weights

Weights	
Rotor blade:	approx. 8.0 t
Hub complete incl. pitch system:	approx. 17.5 t
Nacelle (excl. rotor):	approx. 71.0 t

Table 15: Weights

### 6.2 Dimensions

Dimensions Blade	
Length:	approx. 45.2 m
Height:	approx. 5.0 m

Table 16: Dimensions Blade

Dimensions Hub	
Diameter:	approx. 4.5 m
Height:	approx. 3.4 m

Table 17: Dimensions Hub

Dimensions Nacelle	
Length:	approx. 10.3 m
Height (hood demounted):	approx. 3.9 m
Width:	approx. 3.8 m

Table 18: Dimensions Nacelle

Dimensions Drive Train (rotor shaft and gear box)	
Length:	approx. 4.9 m
Height:	approx. 2.4 m
Width:	approx. 3.0 m

Table 19: Dimensions Drive Train

All values in this document are for information purposes and actual values may vary due to specific conditions.

***Power Curve &  
Sound Power Level  
REpower MM92  
[2050 kW]***

REpower Systems AG  
Überseering 10 / Oval Office  
22297 Hamburg

Tel.: +49 - 40 - 5555090 - 0  
Fax: +49 - 40 - 5555090 - 3999

[www.repower.de](http://www.repower.de)

Copyright © 2008 REpower Systems AG

All rights reserved.

Disclaimer

Protection Notice DIN ISO 16016: The reproduction, distribution and utilization of this document as well as the communication of its contents to others without explicit authorization in writing of REpower Systems AG is prohibited. Offenders will be held liable for the payment of damages. All rights reserved in the event of the grant of a patent, utility model or design.

Please ensure to use the applicable specifications in their latest versions. Images do not necessarily reflect the exact scope of supply and are subject to technical alterations at any time. Please note that this document can not necessarily correspond with the project-specific requirements.

Possible work procedures shown in this product description comply with German and the REpower's own safety provisions and regulations. The national laws of other countries may provide for further safety specifications.

It is essential that all precautionary measures, both project- and country-specific, be strictly complied with. It is the duty of each customer to inform itself, implement and observe these measures.

The applicability and validity of the relevant legal and/or contractual provisions, the technical guidelines, DIN standards and other comparable regulations is not excluded by the contents or demonstrations contained in product description. Moreover these provisions and regulations shall continue to apply without any limitation.

All information contained in this product description are subject to change at any time without notice or approval by the customer.

REpower Systems AG assumes no liability for any errors or omissions in the content of this product description. Legal claims against REpower Systems AG based on damage caused by the use or non-use of the information offered here or the use of erroneous or incomplete information are excluded.

All brands or product names mentioned in this document are the property of their respective holders.

---

## Table of Content

<b>Applicable Documents</b> .....	<b>4</b>
<b>List of Abbreviations and Units</b> .....	<b>4</b>
<b>1 Power Curve and Sound Power Level MM92 2050 kW</b> .....	<b>5</b>
1.1 General Information.....	5
1.2 Conditions for power curve measurement.....	5
1.3 Conditions for sound power level measurement.....	5
<b>2 Guaranteed electrical Power Curve und guaranteed Sound Power Level</b> .....	<b>6</b>
<b>3 Calculated Sound Power Level MM92 2050 kW for sound propagation (for information only)</b> .....	<b>7</b>
3.1 Sound Power Level according to IEC for different Hub Heights .....	7
3.2 Sound Power Level according to FGW Guideline at 95% of rated power.....	7



## Applicable Documents

The documents referred to in the table below are included for information only. Reference to them in this product description does not make them part of the contract.

Title	Document no.

\* If the products referred to in the table above are to be included within the project, the relevant product descriptions in their current version will be amended to the contract.

## List of Abbreviations and Units

Abbreviation/Unit	Description
WEC	Wind Energy Converter (equal to Wind Turbine Generator System [WTGS])
IEC	International Electrotechnical Commission
FGW	Fördergesellschaft Windenergie e.V.
ct	Thrust coefficient
cp	Power coefficient

## 1 Power Curve and Sound Power Level MM92 2050 kW

### 1.1 General Information

Rotor diameter:	92.5 m
Air density:	1.225 kg/m <sup>3</sup>
Cut in wind speed:	approx. 3.0 m/s
Cut out wind speed:	24 m/s
Wind speed at hub height:	10 minutes mean values
Blades:	clean, no ice/snow formation

### 1.2 Conditions for power curve measurement

Verification according to IEC 61400-12-1: 2005<sup>1</sup>

Turbulence intensity:	6 to 12 %
Terrain:	not complex according to IEC 61400-12-1: 2005 <sup>1</sup>
Vertical wind shear coefficient (measured between hub height and hub height minus rotor diameter divided by 2):	≤ 0.2
air density at location (10 minutes mean value):	≥ 1.13 kg/m <sup>3</sup>
Temperature range:	≤ 35 °C
Power factor:	cos phi ~ 1
Anemometer type:	Thies First Class

### 1.3 Conditions for sound power level measurement

Verification according to IEC 61400-11: 2002 + A1: 2006

Roughness length (average peak):	0.05 m
----------------------------------	--------

---

<sup>1</sup> For obstacle assessment according to 61400-12-1: 2005 Annex A.2 the following condition applies:

*No obstacles with a height greater than 1/3 of the distance between the ground and the lower blade tip shall exist in the measurement sector within 0-4 rotor diameters of the wind turbine or met mast.*

## 2 Guaranteed electrical Power Curve und guaranteed Sound Power Level<sup>2</sup>

Wind speed $v$ [m/s] <sup>3</sup>	Power $P$ [kW]	Sound Power Level $L_{WA}$ [dB(A)] <sup>4</sup>	Thrust coefficient ct[-]	Power coefficient cp [-]
3.0	20	--	0.98	0.180
4.0	94	--	0.87	0.357
5.0	205	--	0.79	0.398
6.0	391	100.4	0.79	0.440
7.0	645	101.8	0.79	0.457
8.0	979	103.3	0.79	0.465
9.0	1375	104.2	0.74	0.458
10.0	1795	104.2	0.69	0.436
11.0	2000	104.2	0.54	0.365
12.0	2040	104.2	0.39	0.287
13.0	2050	104.2	0.29	0.227
14.0	2050	104.2	0.23	0.182
15.0	2050	104.2	0.19	0.148
16.0	2050	104.2	0.15	0.122
17.0	2050	104.2	0.13	0.101
18.0	2050	104.2	0.11	0.085
19.0	2050	104.2	0.09	0.073
20.0	2050	104.2	0.08	0.062
21.0	2050	104.2	0.07	0.054
22.0	2050	104.2	0.06	0.047
23.0	2050	104.2	0.06	0.041
24.0	2050	104.2	0.05	0.036

<sup>2</sup> Valid for unrestricted operation only. During sound reduced operation different power and sound levels are effective.

<sup>3</sup> Wind speed at hub height

<sup>4</sup> Sound power level at hub height

### 3 Calculated Sound Power Level MM92 2050 kW for sound propagation (for information only)

#### 3.1 Sound Power Level according to IEC for different Hub Heights

HH	$v_{10}^5$ [m/s]	5.0	6.0	7.0	8.0	9.0	10.0
68.5m	$L_{WA}^6$ [dB(A)]	101.2	103.1	104.2	104.2	104.2	104.2
78.5m	$L_{WA}^6$ [dB(A)]	101.4	103.3	104.2	104.2	104.2	104.2
80m	$L_{WA}^6$ [dB(A)]	101.4	103.3	104.2	104.2	104.2	104.2
100m	$L_{WA}^6$ [dB(A)]	101.7	103.4	104.2	104.2	104.2	104.2

All sound power levels above are based on wind speeds of  $v_{10}$  at 10 m height. The data of the noise level are based on the requirements of the IEC 61400-11 : 2002 + A1 : 2006  
The calculation of the wind speed in 10m height is based on a roughness length of 0.05m, equivalent to a vertical wind shear coefficient of 0.14.

#### 3.2 Sound Power Level according to FGW Guideline at 95% of rated power

The sound power level measured according to the "Technische Richtlinie für Windenergieanlagen Teil 1: Rev. 18 der FGW" at 95% of the rated power is independent of the hub height:

$$L_{WA, 95\%} = 104.2 \text{ dB(A)}$$

---

<sup>5</sup> Wind speed at 10m height

<sup>6</sup> Sound power level at hub height

Fire Safety  
*REpower MD/MM*

---

## Contents

<b>1</b>	<b><i>REpower fire safety MD/MM</i></b> .....	<b>3</b>
<b>1.1</b>	<b>Fire safety</b> .....	<b>3</b>
<b>2</b>	<b><i>Location of fire extinguishers</i></b> .....	<b>4</b>
<b>2.1</b>	<b>In the nacelle</b> .....	<b>4</b>
<b>2.2</b>	<b>At the base of the tower</b> .....	<b>4</b>
<b>3</b>	<b><i>Fire safety concept</i></b> .....	<b>5</b>
<b>4</b>	<b><i>Assessment of the plant-specific fire safety concept to VFDB guideline</i></b> .....	<b>7</b>
<b>4.1</b>	<b>REpower MD/MM with external transformer substation</b> .....	<b>7</b>
4.1.1	Summary	7
<b>4.2</b>	<b>REpower MD/MM with internal transformer</b> .....	<b>7</b>
4.2.1	Summary	7

# 1 REpower fire safety MD/MM

## 1.1 Fire safety

- Waste, dirt, empty containers, in particular also oily, flammable cloths must be removed on job completion.
- When using heat-generating tools such as soldering irons, hot air blowers or grinding tools, the work space must be cleared of all flammable materials and an appropriate safety shield and venting provided around the work place. A fire extinguisher should be within reach during such work.
- In the event of fire in the plant or on its periphery the wind energy converter must be evacuated immediately. This is done by means of abseiling equipment located in the nacelle (second escape route) The main connection must be cut off at the power switch in the control cabinet or transformer substation. Should this not be possible the responsible power company should be notified so that the latter may take the necessary action.
- Fire fighting: fire extinguishers are provided in the nacelle and tower base. CO<sub>2</sub> extinguishers should be used preferably for fires on electrical modules, in other cases, ABC extinguishers.
- If the fire cannot be extinguished immediately a sufficient area should be cordoned off taking into consideration the direction of the wind around the wind energy converter and the responsible police and fire service departments have to be notified.

## 2 Location of fire extinguishers

### 2.1 In the nacelle

1× ABC type GX6. 6 kg

1× CO<sub>2</sub>, 5 kg

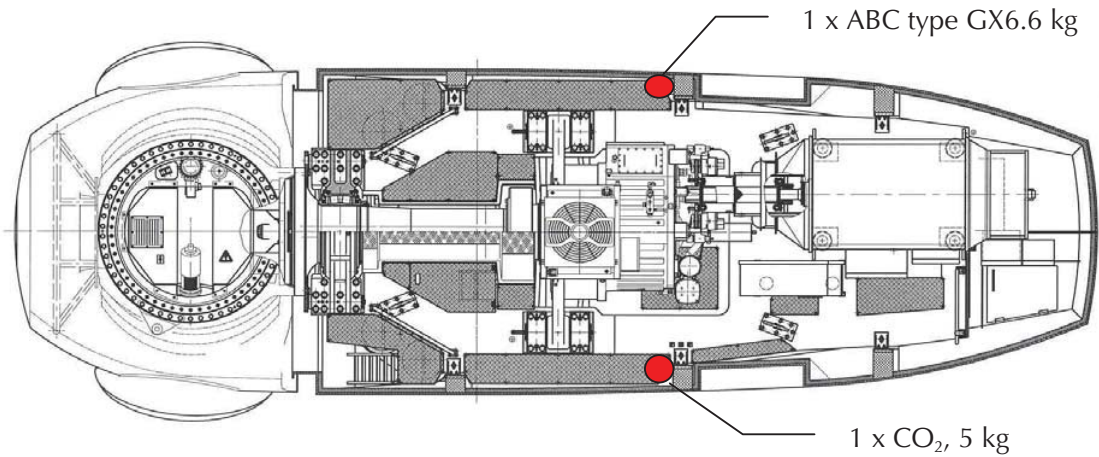

### 2.2 At the base of the tower

1× CO<sub>2</sub>, 5 kg

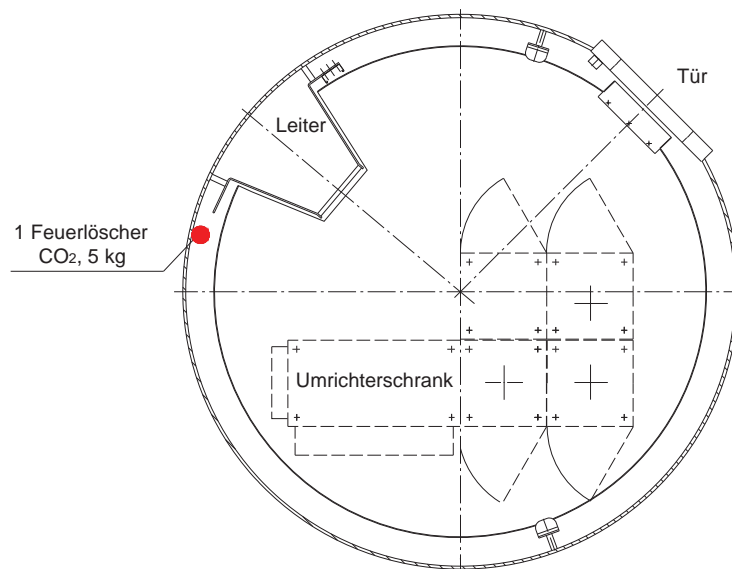



### 3 Fire safety concept

The fire safety concept envisages following situations in the event of a fire occurring in the plant:

1. The plant is in operation or on stand-by and no maintenance personnel are in the plant.
2. The maintenance personnel are entering or leaving the plant and ascending or descending in the tower.
3. The maintenance personnel are in the nacelle for maintenance work.

The entire plant switches off automatically via suitable sensors as soon as one of the electrical or mechanical components indicates that temperatures are too high.

Re 1.) In the event of a fire in the wind energy converter when there are no maintenance personnel in the vicinity and no danger exists to life or limb, the plant may catch fire due to electrical defects.

In the course of which:

- a) Electrical cabinets, inverters and transformer in the tower base may catch fire.
- b) Generator, control and ventilation systems in the nacelle may catch fire.

**In the case of a)** apart from the destruction of the electrical equipment no further damage of relevance will occur. Smoke is channelled to the outside via the vent openings in the nacelle. Since the smoke exits at hub height and the distance to the nearest residential buildings is generally at least 500 m, no danger to the residents is to be expected as the smoke clouds will disperse.

**In the case of b)** the entire nacelle may catch fire and parts of the outer nacelle shell fall off. As fire and smoke development are visible at great distance it may be assumed that persons (farmers at work, people out walking, cyclists) will keep a safe distance from the fire source in the interests of their own personal safety.

Re 2.) warning signs point out that during the ascending or descending of maintenance personnel inside the tower the plant should be switched off to avoid the danger of the stations in the base of the tower catching fire, and the maintenance personnel thus being

endangered by heat and smoke development when ascending or descending in the tower.

If maintenance personnel are in the base of the tower and a fire breaks out in the substation, a suitable fire extinguisher is available. If necessary, the fire service will be called in to assist.

Re 3.) If maintenance personnel are in the nacelle and a fire breaks out in the substation in the base of the tower the maintenance personnel may

- call the fire service to fight the fire
- open the air vents in the nacelle to assure sufficient smoke extraction.

Should the smoke and heat development in the nacelle become too great, maintenance personnel may use the second escape route by use of abseiling equipment. Abseil rescue equipment is featured in the nacelle of every plant. This abseil rescue equipment may be easily handled by one person.

If maintenance personnel are in the nacelle and a fire breaks out in the **nacelle**, the maintenance personnel may

- use the suitable fire extinguishers supplied for fire fighting.
- open the air vents in the nacelle to allow sufficient smoke extraction.

Should it not be possible to extinguish the fire using the available fire extinguishers, the maintenance personnel may reach safety by using the regulation descent inside the tower.

## 4 Assessment of the plant-specific fire safety concept to VFDB guideline

Specific fire safety concepts were developed for REpower plants MD/MM by the officially accredited expert for fire safety inspection, the graduate architect, Hanns-Helge Janssen, Aachen, who assessed the plant with regard to fire safety<sup>1</sup>. The assessments differentiated between WEC variants with external and internal transformers. Summaries of the assessments may be found on the following pages.

### 4.1 REpower MD/MM with external transformer substation

#### 4.1.1 Summary

Of decisive importance for the technical fire safety assessment of planned plants are their very special structural and use-related conditions. The limited prerequisites and options for structural and preventive fire protection are offset by a minimum probability of fire occurrence and a very minor usage concentration – exclusively maintenance or repair and inspection jobs by trained personnel.

The precautions taken to achieve the relevant statutory building protection aims on the basis of these specifications are to be regarded as fully adequate. In the opinion of the undersigned the intention may be assessed as suitable for approval without reservation.

### 4.2 REpower MD/MM with internal transformer

#### 4.2.1 Summary

Of decisive importance for the technical fire safety assessment of planned plants are their very special structural and use-related conditions. The limited prerequisites and options for structural and preventive fire protection are offset by a minimum probability of fire occurrence and a very minor usage concentration – exclusively maintenance or repair and inspection jobs by trained personnel.

The precautions taken to achieve the statutory relevant building protection aims on the basis of these specifications are to be regarded as fully adequate. In the opinion of the undersigned the intention may be assessed as suitable for approval without reservation.

---

<sup>1</sup> see here V-1.1-GP.BS.01-A and V-1.1-GP.BS.02-A in the respectively valid version